

CUT SHEET:

FRAME CABLE



PRODUCT OVERVIEW

The SageGlass® Frame Cable connects the SageGlass insulating glass units (IGUs) to the control system. More specifically, it attaches to the IGU pigtail on one end, is routed through the glazing's framing system, and connects to the control system either at the terminal box or directly at the control panel. It can be ordered in a variety of lengths and conductor configurations to meet specific installation requirements. The plenum rated, PVC-insulated Frame Cable wires are 22 gauge.

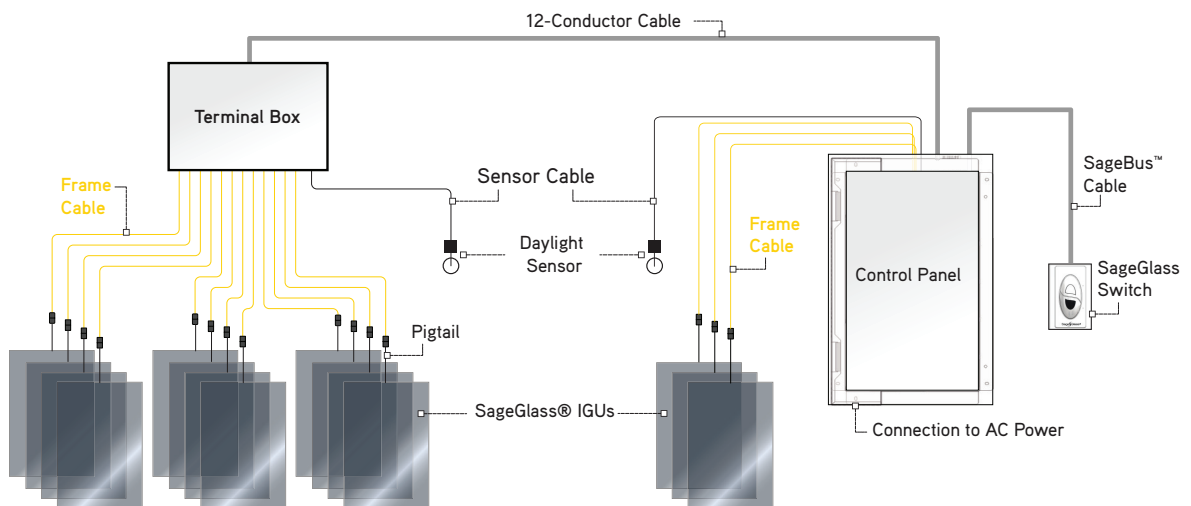

The Frame Cable runs through the framing system, connecting the SageGlass IGU to the terminal box. Alternatively, the Frame Cable can run from the IGU Pigtail directly to the Control Panel. The different available configurations allow flexibility in the design of the system to accommodate the requirements of each individual project.

PRODUCT DIMENSIONS

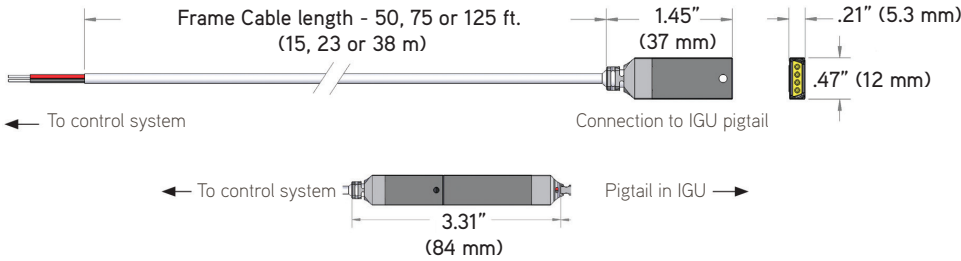

Frame Cable is joined to the IGU pigtail with an easy-snap connector.

SAGE PART NUMBER	CABLE LENGTH	CONDUCTORS*	NOMINAL DIAMETER
330-0007-007	50 ft. (15 m)	2	0.116" (2.95 mm)
330-0009-007		3	0.122" (3.10 mm)
330-0011-007		4	0.136" (3.45 mm)
330-0007-008	75 ft. (23 m)	2	0.116" (2.95 mm)
330-0009-008		3	0.122" (3.10 mm)
330-0011-008		4	0.136" (3.45 mm)
330-0007-010	125 ft. (38 m)	2	0.116" (2.95 mm)
330-0009-010		3	0.122" (3.10 mm)
330-0011-010		4	0.136" (3.45 mm)

*The number of conductors is based upon IGU and project configuration.

INSTALLATION REQUIREMENTS

To protect the cable from damage while routing it through the framing system, SageGlass provided grommets should be used. A 3/8" (10mm) hole is required to install grommet. Frame Cables should be conditioned for 24 hours at room temperature prior to installation. The cables should never be installed below 32° F (0° C) ambient temperature. Once installed, the cables must not be exposed to sunlight, even through glass. If they are installed in an exposed location, they must be covered or painted (latex/water-based paint only). Non-adherence to these guidelines will void the warranty.

GET IN TOUCH

SageGlass® is the pioneer of the world's smartest dynamic glass and is transforming the indoor experience for people by connecting the built and natural environments. Electronically tintable SageGlass tints or clears on demand to control sunlight and prevent heat and glare without the need for blinds or shades. SageGlass dramatically reduces energy demand and the need for HVAC by blocking up to 91 percent of solar heat. As part of Saint-Gobain, SageGlass is backed by more than 350 years of building science expertise that only the world leader in sustainable environments can provide.

(877)724-3321

archsolutions@sageglass.com

www.sageglass.com



RATINGS & CERTIFICATIONS

Plenum rated
IP67
Temperature rated -4° to 167° F (-20° to 75° C)
CL2P certified
RoHS certified

ORDERING INFORMATION

SAGE PART NUMBER
330-0007-007
330-0009-007
330-0011-007
330-0007-008
330-0009-008
330-0011-008
330-0007-010
330-0009-010
330-0011-010

CONDUCTOR COUNT

CORRECT CABLE (2C, 3C, OR 4C) MUST BE USED PER WIRING/ELEVATION DIAGRAM

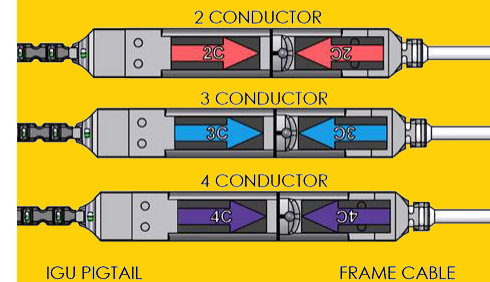

SAGE Electrochromics, Inc.
2 Sage Way • Faribault, MN 55021 USA

© SAGE Electrochromics, Inc. All rights reserved. SageGlass is a registered trademark of SAGE Electrochromics, Inc. SCS-004.3